

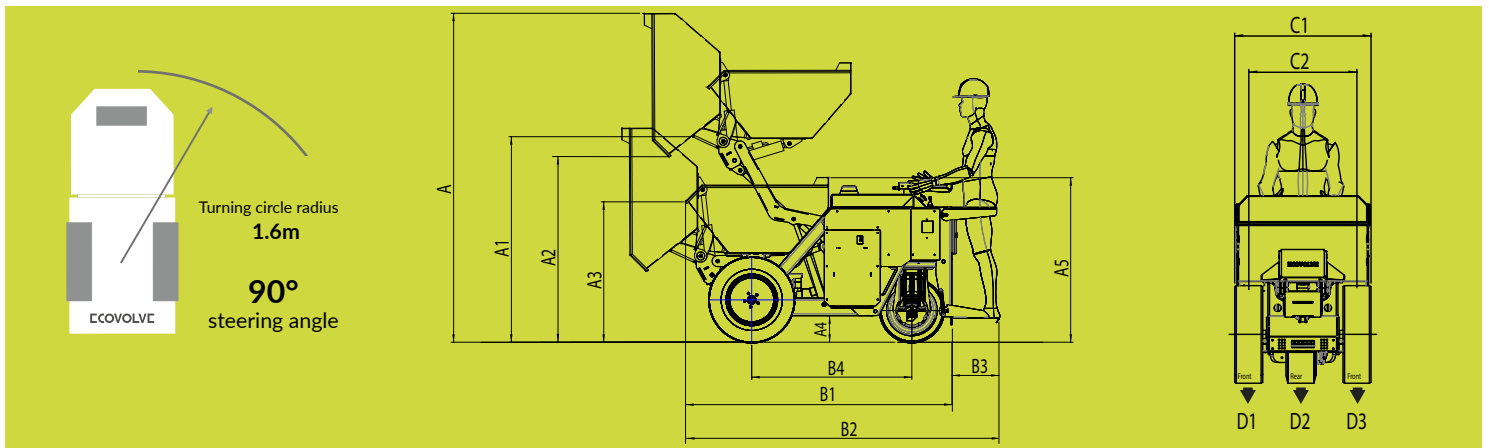

		ED1000	
Capacity	Max safe load (Kg)	1000	
	Unladen weight (Kg)	1300	
	Skip - Levelled (Ltr)	435	
	- Heaped (Ltr)	600	
	- Water level (Ltr)	315	
Drive	Drive type	1 wheel drive	
	Steering	1 wheel steer	
	Speed (Km/h)	0-8	
	Steering angle	90°	
	Grade ability	15°	
Transmission	Proportional Steering	Drive Electric	
	Tires - Front (2no. Super elastic)	27x8,5x15	
	- Rear (1no. Super elastic)	21x8x9	
	Brakes	Dynamic electric brake Negative parking brake	
Hydraulic system	Gear pump - Flow rate (Ltr/Min)	6.5	
	- Oper. pressure (Bar)	130	
	Pump motor (KW)	2.2	
	Hydraulic tank capacity (Ltr)	2.8	
Electric system	Voltage (V)	24	
	Battery (Ah)	400	
	Integrated Charging - Input (V AC)	100-240	
	- Output (V DC)	24	
	Recharge (Hrs)	8	
Drive motor	Type	Induction motor	
	Output	5KW/7HP	
	Emission	Zero	
Noise	Driving (Db)	65	
	Buzzer [adjustable] (Db)	60-80	



[mm]													Unladen		Laden	
	A	A1	A2	A3	A4	A5	B1	B2	B3	B4	C1	C2	D1/D3	D2	D1/D3	D2
ED800	2610	1630	1470	1120	210	1310	2065	2388	330	1270	813	584	280 kg	680 kg	650 kg	700 kg
ED1000	2610	1630	1470	1120	210	1310	2200	2565	330	1270	965	762	310 kg	680 kg	785 kg	730 kg
ED1500	2900	1800	1600	1150	210	1340	2245	2575	330	1326	1173	975	375 kg	750 kg	1125 kg	750 kg

Ground Pressure